







Irrigation Feeder System Installation Guide

Siphoning System for sprinkler systems with above-ground well pumps

Also from American Hydro Systems

Rust Stain Prevention		Specialty Products	
 Formula 500 Original Formula	 Formula 1000 Acidic Well Water Formula	 Stain Cleaner Liquid Formula	 GrassSoGreen Liquid Fertilizer
 Formula 2000 Hard Well Water Formula	 Formula 3000 Extreme Well Water Formula	 The PumpHaus Pump Cover	American Hydro Systems provides complete solutions for treating irrigation well water.

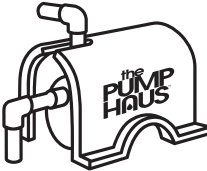

Specialized Products
for a Clean & Green Landscape

1-866-357-5063

www.americanhydro.com

Irrigation Feeder Systems | Rid O' Rust Stain Remover | GrassSoGreen
Rid O' Rust Preventer Formulas | The PumpHaus

Distributed by:

Pro Products

Ft. Wayne, Indiana 46804

Part #2650MANUAL

Irrigation Feeder System Installation Guide

Type: Siphoning System



The complete solution for treating irrigation well water.

Follow these easy steps to install your American Hydro Systems Irrigation Feeder System.
It's designed to help you get rid of rust stains and scale
and keep your landscape clean & green.

Irrigation Feeder System: Siphoning Type



These items are included in the Siphoning System kit:

1. Heavy Duty 30 Gallon Tank and Lid
2. All Inside Parts
3. In-Line Filter with Metering Jet
4. 6' – 3/8" Vinyl Tubing
5. 1/4" Check Valve
6. Saddle Clamp
7. Water Test Kit
8. Owner's Manual

How to Choose the Right Location for the Siphoning System:

We recommend that your Siphoning System be placed in a well-ventilated location within 6 feet of the pump. You may hide the tank behind a wall, fence, or shrubs. Set the tank on a smooth, level surface such as a patio block or concrete slab. We advise against burying the tank; you won't be able to see the water level in the tank and will find servicing it difficult.

Installation Instructions:

There are Three Easy Ways to Install your Siphoning System.

Remember that the siphoning system can only be installed on the intake (suction) side of an above ground centrifugal pump. If you install it on the discharge side, you will only create a big leak in your irrigation system.

Before you install, shut off the electricity to the well pump and read these instructions!

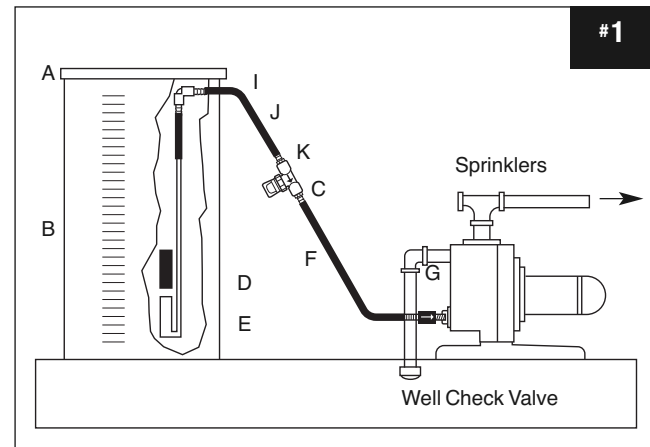

#1 The Easiest Way Possible

(May not apply with all pumps)

Tools needed: Wrench or pliers and plumber's tape.

Steps:

1. Unscrew the drain plug from the bottom portion of your well pump head.
2. Screw the grey check valve (G) into the drain plug hole. (Note: Before installing check valve, ensure that the threads of the plug are the same size as the check valve.) Add several wraps of plumber's tape to the check valve thread to ensure a proper seal.
3. Go to "Start Up" after reading comment below.

Very Important Comment That You Must Read:

In order to operate properly, the siphoning system must be installed on the suction side (intake side) of your pump. Some models of pumps do not create suction at the drainhole. If this is the case, solution will not be drawn out of the tank when you turn on the pump. If so, turn off the pump, unscrew the check valve, replace the drain plug and go to installation #2 or #3.

Bad luck!

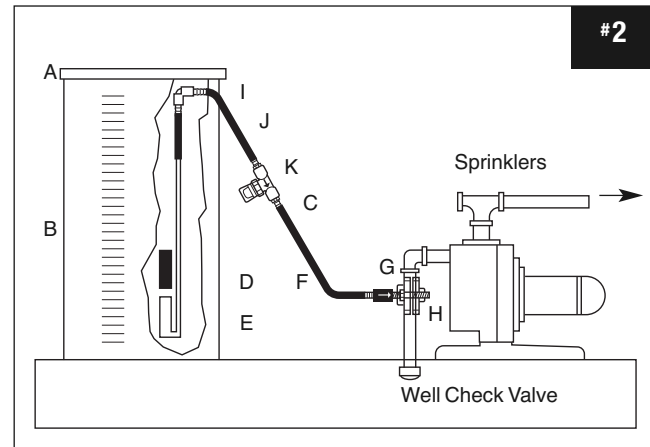

#2 The Second Easiest Way Possible

Tools needed: Drill with 1/4" bit, phillips head screw driver, plumbers tape and saddle clamp.

NOTE: Saddle clamp only works with 1 1/4" PVC pipe.

Steps:

1. Using a phillips head screwdriver, attach the saddle clamp (H) to the suction line of the well pump. The saddle clamp should be placed between the check valve for the well (Note: This may be underground) and the intake side of the well pump.
2. Drill a 1/4" inch hole into the center of the threaded opening of the installed saddle clamp. (Note: If your pump has a pressure tank, turn power off to pump and open up any water valve to relieve pressure from your water line before drilling into pipe).
3. Screw the grey check valve (G) into the saddle clamp. (Note: Add several wraps of plumber's tape to the check valve threads to ensure a proper seal).
4. Go to "Start Up."

Installation Diagram Key	
Item	Description
A	Tank Top
B	Tank
C	Metering Jet
D	Food Valve Sleeve
E	Foot Valve
F	6' Tubing
G	Check Valve
H	Saddle Clamp
I	Threaded Nylon Fitting
J	6" Tubing
K	In-line Filter

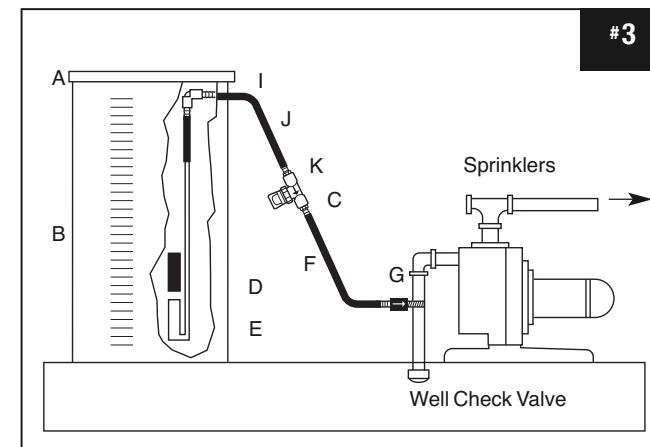

#3 The Third Easiest Way Possible

Tools needed: Drill with 7/16" bit, 1/4" pipe tap, and plumber's tape.

Steps:

1. Drill a 7/16" hole into the suction line of pump. The hole should be drilled as close to ground level as possible between the check valve for the well (Note: This may be underground) and the intake side of the well pump. If your pump has a pressure tank, turn the power off to the pump and open any water valve to relieve pressure from your water line before drilling into pipe.
2. Thread the hole with a 1/4" NPT pipe tap.
3. Screw the grey check valve (G) into the hole that you have just drilled and tapped. (Note: Add several wraps of plumber's tape to the check valve threads to ensure a proper seal).
4. Go to "Start-Up."

Start Up, Final Check-out & Operation:

Start Up

1. Attach the free end of the 6" of clear vinyl tubing (J) to the barbed end of the threaded nylon fitting (I) on the side of the tank and attach the free end of the 6' of tubing (F) to the barbed end of the check valve (G). Secure both ends with provided zipties.
2. Fill the tank 1/2 full of water. It is preferable to use municipal or soft water when available.
3. Turn on the sprinkler pump and sprinkler zone. Watch the clear vinyl tubing (F) and the clear housing of the in-line filter (K). Water should appear in about 30 seconds to a minute as a thin continuous stream from the metering jet (C) that is attached to the in-line filter. If it does, congratulations, your system is ready to run.

4. If it does not, the foot valve (E) in the tank is likely not operating correctly. Shut off the pump. Shake the foot valve vigorously, whacking it against the side of the tank. This will purge trapped air from the foot valve and free up the float ball that is enclosed in the foot valve housing.

5. SEE #3 above.

6. Add chemical according to dosage recommendations in your Owner's Manual or on our website and fill the tank up to the 30 gallon mark. Note: Make sure to have your well water tested to ensure you have the correct Rid O'Rust Formula for your type of water.

7. When the tank is filled up, add 2 cups of household bleach to prevent algae growth in the tank.

Final Check-out and Operation

1. Turn on the sprinkler system. Watch for a thin stream of solution flowing from the metering jet (C) in to the clear tubing (F) by letting your sprinkler system run for several minutes. Turn off the pump to see if the liquid level in the clear tubing holds. If the well pump's check valve and the siphoning system check valve (G) are installed properly, the solution in the clear tubing will not continue to siphon out.
2. Generally, the liquid level in the tank will drop one gallon per hour of operation (based on a 1 horse power pump). To ensure continuous treatment, refill the tank before it drops below the top of the foot valve (E) in the bottom of your tank.

Guidelines for Using Products in Your Irrigation Feeder System:

Caution:

The American Hydro Systems Irrigation Feeder System works with Rid O' Rust rust preventer formula and GrassSoGreen liquid fertilizer. GrassSoGreen is formulated to be mixed in the same tank with the Rid O' Rust formula. However, the nitrogen in the fertilizer will react with bleach if mixed together at the same time. Allow the fertilizer to mix thoroughly with water before slowly and carefully adding bleach. ONLY add bleach after the tank has been filled with water. Again, the feeder tank should be located in a well-ventilated place.

The use of any other chemicals such as pesticides or herbicides is prohibited. These can be harmful to plants and animals and will likely damage the system. Use of these chemicals or any other chemicals not manufactured by Pro Products will void the warranty.