

Submersible Motor Controls

Standard controls for single-phase 3-wire submersible motors

PENTEK offers a full range of 1/2 - 15 HP models that are interchangeable with existing motor controls for Capacitor Start/Induction Run (CSIR) and Capacitor Start/Capacitor Run (CSCR) applications. PENTEK is the professional choice in harsh and high temperature installations.

1/2 - 15 HP, Single-Phase Controls, 50/60 Hz

APPLICATIONS

Water systems...for residential, multiple housing, farm and commercial installations, where a submersible 3-wire motor is used.

DESIGN FEATURES

Enclosure

- ▶ Rugged NEMA 3R Enclosure – suitable for indoor/outdoor use
- ▶ NEW HardBond™ Finish – 5-times more corrosion-resistant
- ▶ Multiple-Size Electrical Knockouts

Internals

- ▶ High-Load Voltage Relay
- ▶ Heavy-Duty Contacts
- ▶ External Access to Overload Reset – CSCR
- ▶ Heavy-Duty Terminal Connectors – suitable for up to #4 AWG wire
- ▶ Industry Standard Wiring Connections – easy-to-read wiring diagrams
- ▶ Overload protection built-in (50Hz models)

Agency Approvals

- ▶ UL 778 and CUL recognized (60Hz)

PENTEK Submersible Motor Controls can be used with PENTEK XE Series and other 4" single-phase motors.

SIZE A

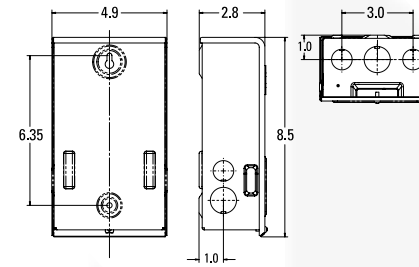

SIZE B

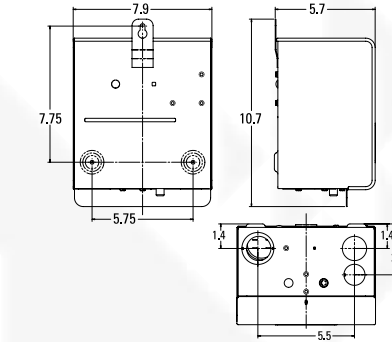

SIZE C

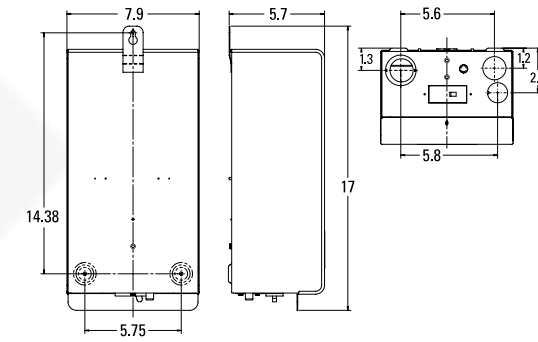

CSIR – Capacitor Start/Induction Run

HP	KW	PHASE	VOLTS	WEIGHT		BOX SIZE	ENCL. SIZE	60 HZ CATALOG NO.	50 HZ CATALOG NO.
				LBS.	KG				
1/2	0.37	1	115	4	1.8	5.5" x 3.25" x 9"	A	SMC-IR0511 (-6pk)*	-
1/2	0.37	1	230	4	1.8	5.5" x 3.25" x 9"	A	SMC-IR0521 (-6pk)*	-
3/4	0.55	1	230	4	1.8	5.5" x 3.25" x 9"	A	SMC-IR0721 (-6pk)*	-
1	0.75	1	230	4	1.8	5.5" x 3.25" x 9"	A	SMC-IR1021 (-6pk)*	-

CSCR – Capacitor Start/Capacitor Run

HP	KW	PHASE	VOLTS	WEIGHT		BOX SIZE	ENCL. SIZE	60 HZ CATALOG NO.	50 HZ CATALOG NO.
				LBS.	KG				
1/2	0.37	1	230	5	2.3	5.5" x 3.25" x 9"	A	SMC-CR0521 (-6pk)*	SMC5-CR0521
3/4	0.55	1	230	5	2.3	5.5" x 3.25" x 9"	A	SMC-CR0721 (-6pk)*	SMC5-CR0721
1	0.75	1	230	5	2.3	5.5" x 3.25" x 9"	A	SMC-CR1021 (-6pk)*	SMC5-CR1021
1-1/2	1.1	1	230	7	3.2	8.125" x 6.25" x 11"	B	SMC-CR1521	SMC5-CR1521
2	1.5	1	230	7	3.2	8.125" x 6.25" x 11"	B	SMC-CR2021	SMC5-CR2021
3	2.2	1	230	7	3.2	8.125" x 6.25" x 11"	B	SMC-CR3021	SMC5-CR3021
5	3.7	1	230	8	3.6	8.125" x 6.25" x 11"	B	SMC-CR5021	SMC5-CR5021
7-1/2	5.5	1	230	12	5.4	8.125" x 6.25" x 18"	C	SMC-CR7521	-
10	7.5	1	230	14	6.4	8.125" x 6.25" x 18"	C	SMC-CR10021	-

CSCR PLUS – Capacitor Start/Capacitor Run PLUS Magnetic Contactor

HP	KW	PHASE	VOLTS	WEIGHT		BOX SIZE	ENCL. SIZE	60 HZ CATALOG NO.	50 HZ CATALOG NO.
				LBS.	KG				
2	1.5	1	230	7	3.2	8.125" x 6.25" x 11.25"	B	SMC-CRP2021	SMC5-CRP2021
3	2.2	1	230	8	3.6	8.125" x 6.25" x 11.25"	B	SMC-CRP3021	SMC5-CRP3021
5	3.7	1	230	12	5.4	8.125" x 6.25" x 18"	C	SMC-CRP5021	SMC5-CRP5021
7-1/2	5.5	1	230	14	6.4	8.125" x 6.25" x 18"	C	SMC-CRP7521	-
10	7.5	1	230	15	6.8	8.125" x 6.25" x 18"	C	SMC-CRP10021	-
15	11	1	230	17	7.7	8.125" x 6.25" x 18"	C	SMC-CRP15021	-

CSCR PLUS – Capacitor Start/Capacitor Run PLUS Magnetic Contactor for PENTEK 6" Motor

HP	KW	PHASE	VOLTS	WEIGHT		BOX SIZE	ENCL. SIZE	60 HZ CATALOG NO.	50 HZ CATALOG NO.
				LBS.	KG				
5	3.7	1	230	12	5.4	8.125" x 6.25" x 18"	C	SMCP-CRP5021	-
7.5	5.5	1	230	14	6.4	8.125" x 6.25" x 18"	C	SMCP-CRP7521	-
10	7.5	1	230	15	6.8	8.125" x 6.25" x 18"	C	SMCP-CRP10021	-
15	11	1	230	17	7.7	8.125" x 6.25" x 18"	C	SMCP-CRP15021	-

* Submersible Motor Controls are available in single and six packs. Include the suffix '-6pk' after the PN if 6 packs are required.

