

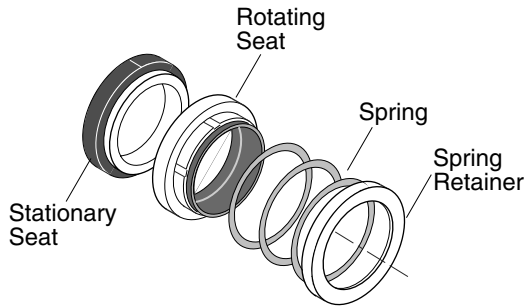

TYPE "B" SINGLE STAGE CENTRIFUGAL PUMP Electric Motor Drive

Section	CC
Supplement	B
Date	January 1, 2004
Supersedes 6/1/95	

MECHANICAL SEAL CONSTRUCTION



Typical Mechanical Seal

Standard Mechanical Seal/ Shaft Sleeve Combinations

SEAL		SLEEVE	
P/N	Description	P/N	Description
S32013	1-1/4" Type 21 Long	S00619	1" I.D. x 1-1/4" O.D.
S32014	1-1/4" Type 21 Short	S19310	1" I.D. x 1-1/4" O.D.
S32015	1-3/4" Type 21 Short	S18869	1-3/8" I.D. x 1-3/4" O.D.
M10227	1-3/4" Type 2	S18869	1-3/8" I.D. x 1-3/4" O.D.
S32016	2-1/8" Type 21 Long	S07073	1-3/4" I.D. x 2-1/8" O.D.
S39264	2-1/8" Type 21 Short	M09669	1-3/4" I.D. x 2-1/8" O.D.
S32697	2-3/4" Type 21	S29517	2-1/4" I.D. x 2-3/4" O.D.

PACKING CONSTRUCTION

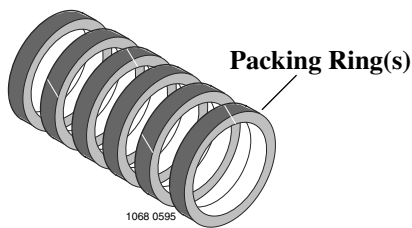

Typical Packing Set - Soft Rings Only

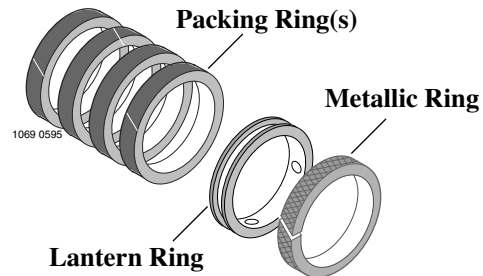

Typical Packing Set With Soft Rings,
Lantern Ring, and Hard (Metallic) Ring

Standard Packing Sets Shown on Repair Parts Sheets

Packing Set P/N	No. of Soft Rings	Metallic Ring	Ring I.D.	Ring O.D.	Cross Section
S14109	5	None	1-1/4"	1-7/8"	5/16"
S13469	6	None	1-1/4"	1-7/8"	5/16"
S15094	7	None	1-1/4"	1-7/8"	5/16"
S13435	4	S11092	1-3/4"	2-1/2"	3/8"
S13470	6	None	1-3/4"	2-1/2"	3/8"
S13437	4	S11093	2-1/8"	2-7/8"	3/8"
S13444	5	S11093	2-1/8"	2-7/8"	3/8"
S16448	5	S14327	2-3/4"	3-3/4"	1/2"

NOTE: Part numbers given on repair parts sheets for packing rings reflects complete set of soft rings required for each model. Some models also require a hard (metallic) ring that is installed as shown above. Hard ring comes as part of the set, when required, and is in *addition* to the soft ring count shown (set of 5, set of 6, etc.). Metallic part number shown for reference only. Lantern Ring (item #29) is sold separately.